

DISCOVER THE FIREPLACE OF YOUR DREAMS!



TECHNICAL SPECIFICATIONS

GAS FIRES



ELEMENT





A FIREPLACE THAT MATCHES YOUR DNA...

"At Element4 we have a clear ambition: to make the impossible come true. We love to think outside of the box. This results in a wide range of innovative fireplaces with powerful designs and beautiful flame pictures. It is precisely this combination that ensures that our brand is loved worldwide by design enthusiasts and architects alike.

Our promise? A fireplace with great features that will enhance any interior.
We hope to convince you of that also."

A handwritten signature in black ink, appearing to read 'Jan Kempers', written on a light grey background.

Jan Kempers
President and Founder

TABLE OF CONTENTS

Fireplace	Specifications
Gasfire Front	
CUPIDO 50	PAGE 6
CUPIDO 70	PAGE 7
SUMMUM 70 F	PAGE 8
MODORE 100	PAGE 9
SUMMUM 100 F	PAGE 10
MODORE 140	PAGE 11
SUMMUM 140 F	PAGE 12
MODORE 185	PAGE 13
SUMMUM 190 F	PAGE 14
MODORE 240	PAGE 15
SKY SMALL FRONT	PAGE 16
SKY MEDIUM FRONT	PAGE 17
SKY LARGE FRONT	PAGE 18
Gasfire See-through	
TENORE 140	PAGE 19
SUMMUM 140 T	PAGE 20
TENORE 240	PAGE 21
SKY SMALL TUNNEL	PAGE 22
SKY MEDIUM TUNNEL	PAGE 23
SKY LARGE TUNNEL	PAGE 24
Gasfire 3-Sided/ Bay	
SUMMUM 70 3/S	PAGE 25

TABLE OF CONTENTS

Fireplace	Specifications
Gasfire 3-Sided/ Bay	
TRISORE 100	PAGE 26
SUMMUM 100 3/S	PAGE 27
TRISORE 140	PAGE 28
SUMMUM 140 3S	PAGE 29
SUMMUM 190 3S	PAGE 30
Gasfire Corner	
SUMMUM 70 C	PAGE 31
BIDORE 100	PAGE 32
SUMMUM 100 C	PAGE 33
BIDORE 140	PAGE 34
SUMMUM 140 C	PAGE 35
SUMMUM 190 C	PAGE 36
Gasfire Peninsula	
LUCIUS 140	PAGE 37
SUMMUM 140 RD	PAGE 38
SKY SMALL ROOMDIVIDER	PAGE 39
SKY MEDIUM ROOMDIVIDER	PAGE 40
SKY LARGE ROOMDIVIDER	PAGE 41
Gasfire Island	
SUMMUM 140 4/S	PAGE 42
Gasfire Stove	
OVATION	PAGE 43
Gasfire Front	
MODORE 140 OUTDOOR	PAGE 44
SKY SMALL FRONT OUTDOOR	PAGE 45

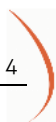

TABLE OF CONTENTS

Fireplace	Specifications
Gasfire Front	
SKY MEDIUM FRONT OUTDOOR	PAGE 46
SKY LARGE FRONT OUTDOOR	PAGE 47
Gasfire See-through	
SKY SMALL TUNNEL OUTDOOR	PAGE 48
SKY MEDIUM TUNNEL OUTDOOR	PAGE 49
SKY LARGE TUNNEL OUTDOOR	PAGE 50



Gasfire

CUPIDO 50

Real Flame Burner	
Natural gas (min-max):	10,000 - 35,500 BTU
Propane (min-max):	8,500 - 28,000 BTU
Efficiency:	88%
Energy efficiency class:	B
Venting ø (inch):	4" x 6"
Black steel:	(Standard)
Black reflective panels:	(Optional)
Connect to home automation:	(Optional)
Operation via app - wifi kit (ProControl):	(Optional)
Powerfan:	(Optional)
Anti-reflective glass:	(Optional)
Access door:	(Optional)
Remote control:	(Standard)
Convection grills built-in and surface-mounted:	(Optional)

CUPIDO 50

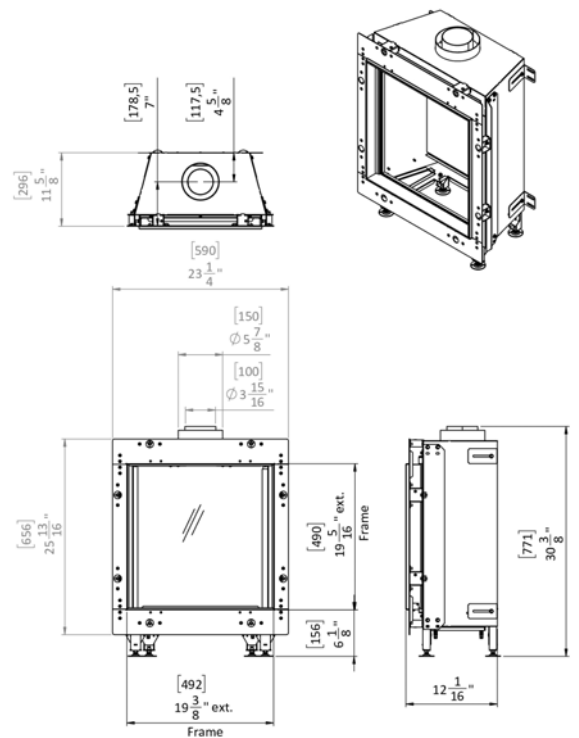



Gasfire

CUPIDO 70

Real Flame Burner	
Natural gas (min-max):	10,000 - 35,500 BTU
Propane (min-max):	8,500 - 28,000 BTU
Efficiency:	88%
<hr/>	
Energy efficiency class:	B
Venting \varnothing (inch):	4" x 6"
<hr/>	
Black steel:	(Standard)
Black reflective panels:	(Optional)
<hr/>	
Connect to home automation:	(Optional)
Operation via app - wifi kit (ProControl):	(Optional)
Powerfan:	(Optional)
Anti-reflective glass:	(Optional)
Access door:	(Optional)
Remote control:	(Standard)
Convection grills built-in and surface-mounted:	(Optional)

CUPIDO 70

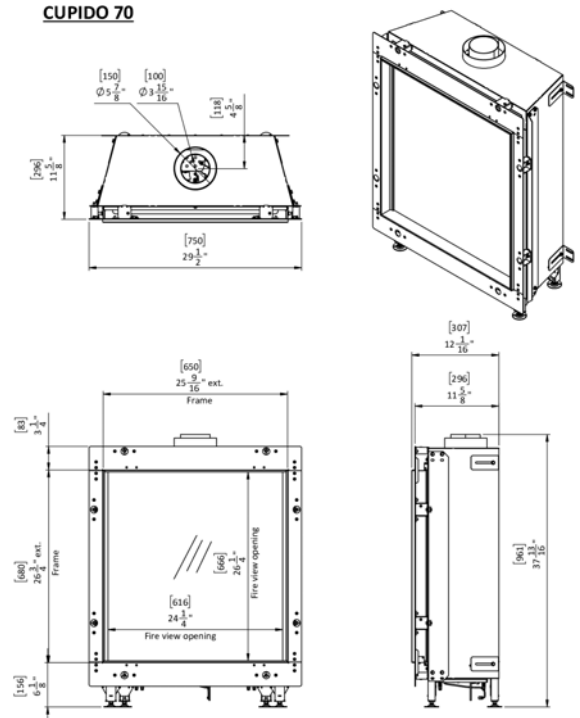



Gasfire

SUMMUM 70 F

Real Flame Burner	
Natural gas (min-max):	13,375 - 33,439 BTU
Propane (min-max):	10,509 - 26,273 BTU
Efficiency:	88%
<hr/>	
Energy efficiency class:	B
Venting \varnothing (inch):	5" x 8"
<hr/>	
Black steel:	(Standard)
Black reflective panels:	(Optional)
<hr/>	
Connect to home automation:	(Optional)
Operation via app - wifi kit (ProControl):	(Optional)
Powerfan:	(Optional)
Anti-reflective glass:	(Optional)
Access door:	(Optional)
Remote control:	(Standard)
Convection grills built-in and surface-mounted:	(Optional)

SUMMUM 70 F

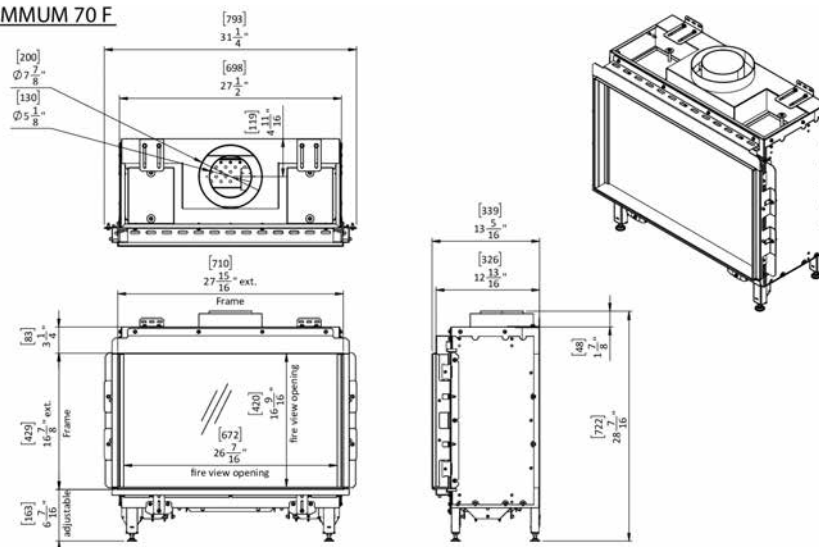



Gasfire

MODORE 100

Single burner	
Natural gas (min-max):	17,050 - 36,200 BTU
Propane (min-max):	13,650 - 32,400 BTU
Efficiency:	83%
<hr/>	
Energy efficiency class:	B
Venting \varnothing (inch):	5" x 8"
<hr/>	
Black steel:	(Standard)
Black reflective panels:	(Optional)
<hr/>	
Connect to home automation:	(Optional)
Operation via app - wifi kit (ProControl):	(Optional)
Powerfan:	(Optional)
Anti-reflective glass:	(Optional)
Access door:	(Optional)
Remote control:	(Standard)
Convection grills built-in and surface-mounted:	(Optional)

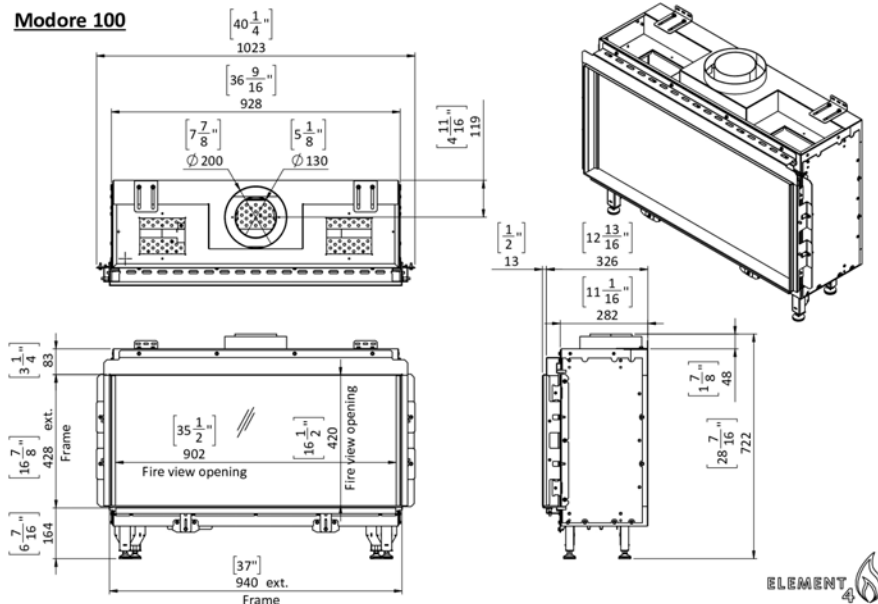



Gasfire

SUMMUM 100 F

Real Flame Burner	
Natural gas (min-max):	13,000 - 50,000 BTU
Propane (min-max):	9,000 - 45,000 BTU
Efficiency:	89%
<hr/>	
Energy efficiency class:	A
Venting \varnothing (inch):	5" x 8"
<hr/>	
Black steel:	(Standard)
Black reflective panels:	(Optional)
<hr/>	
Connect to home automation:	(Optional)
Operation via app - wifi kit (ProControl):	(Optional)
Powerfan:	(Optional)
Anti-reflective glass:	(Optional)
Access door:	(Optional)
Remote control:	(Standard)
Convection grills built-in and surface-mounted:	(Optional)

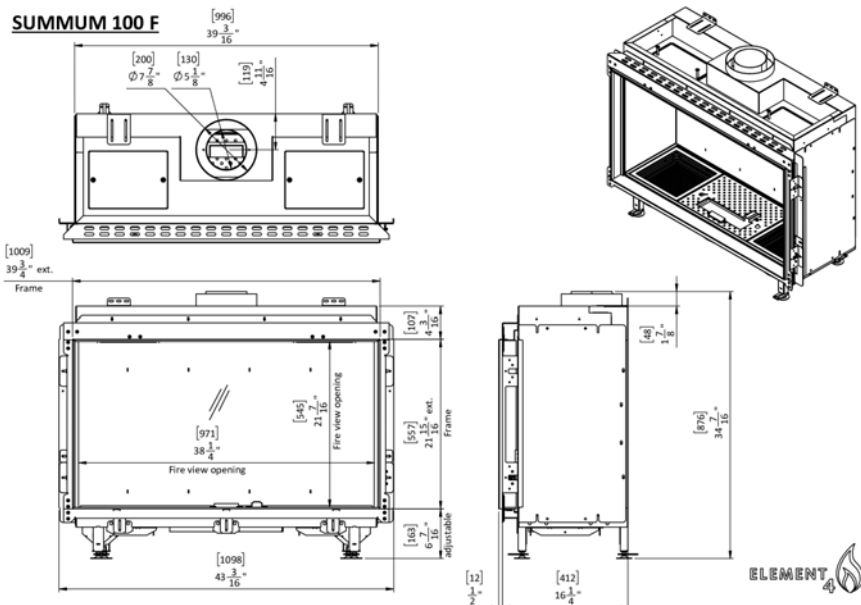



Gasfire

MODORE 140

Double burner	
Natural gas (min-max):	13,650 - 38,200 BTU
Propane (min-max):	11,950 - 34,100 BTU
Efficiency:	90%
<hr/>	
Energy efficiency class:	A
Venting \varnothing (inch):	5" x 8"
<hr/>	
Black steel:	(Standard)
Black reflective panels:	(Optional)
<hr/>	
Connect to home automation:	(Optional)
Operation via app - wifi kit (ProControl):	(Optional)
Powerfan:	(Optional)
Anti-reflective glass:	(Optional)
Access door:	(Optional)
Remote control:	(Standard)
Convection grills built-in and surface-mounted:	(Optional)

MODORE 140

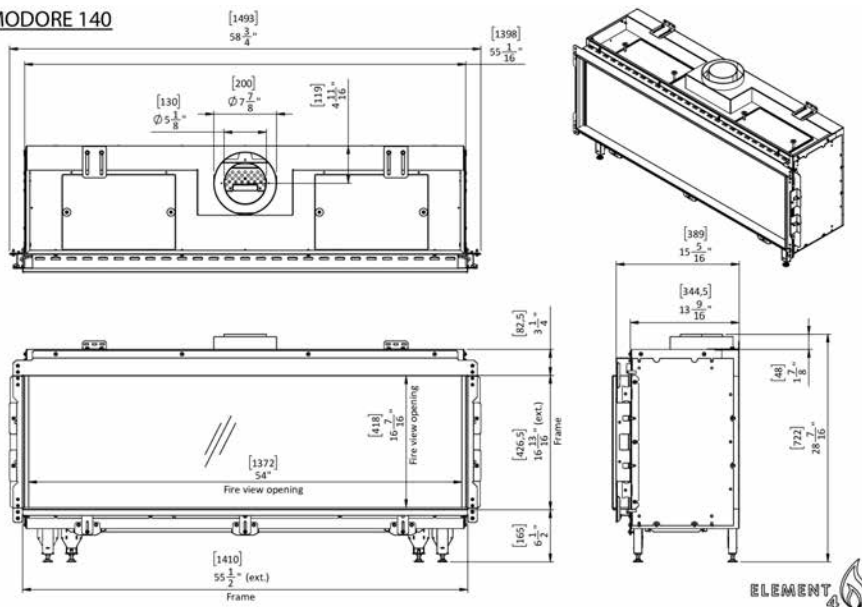



Gasfire

SUMMUM 140 F

Real Flame Burner	
Natural gas (min-max):	20,463 - 81,341 BTU
Propane (min-max):	19,955 - 80,544 BTU
Efficiency:	90%

Energy efficiency class:	A
Venting \varnothing (inch):	5" x 8"

Black steel:	(Standard)
Black reflective panels:	(Optional)

Connect to home automation:	(Optional)
Operation via app - wifi kit (ProControl):	(Optional)
Powerfan:	(Optional)
Anti-reflective glass:	(Optional)
Access door:	(Optional)
Remote control:	(Standard)
Convection grills built-in and surface-mounted:	(Optional)

SUMMUM 140 F

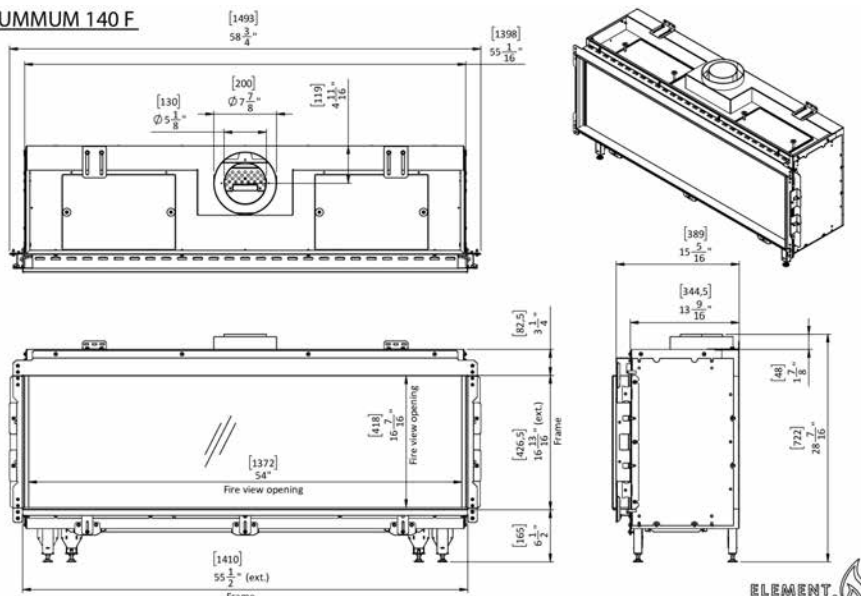



Gasfire

MODORE 185

Multi burner	
Natural gas (min-max):	10,919 - 44,699 BTU
Propane (min-max):	9,213 - 46,746 BTU
Efficiency:	90%
<hr/>	
Energy efficiency class:	A
Venting \varnothing (inch):	5" x 8"
<hr/>	
Black steel:	(Standard)
Black reflective panels:	(Optional)
<hr/>	
Connect to home automation:	(Optional)
Operation via app - wifi kit (ProControl):	(Optional)
Powerfan:	(Optional)
Anti-reflective glass:	(Optional)
Access door:	(Optional)
Remote control:	(Standard)
Convection grills built-in and surface-mounted:	(Optional)

Modore 185

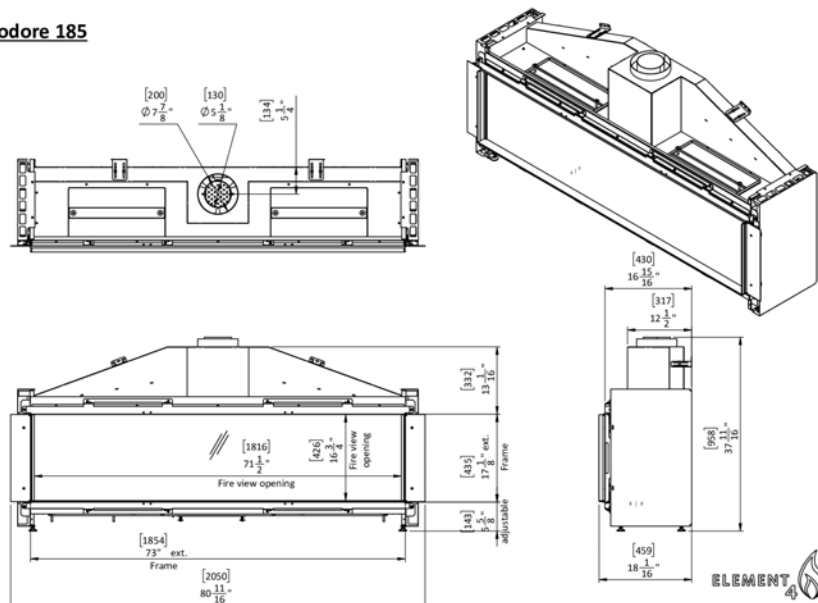



Gasfire

SUMMUM 190 F

Real Flame Burner	
Natural gas (min-max):	20,463 - 81,341 BTU
Propane (min-max):	19,955 - 80,544 BTU
Efficiency:	89%

Energy efficiency class:	A
Venting \varnothing (inch):	5" x 8"

Black steel:	(Standard)
Black reflective panels:	(Optional)

Connect to home automation:	(Optional)
Operation via app - wifi kit (ProControl):	(Optional)
Powerfan:	(Optional)
Anti-reflective glass:	(Optional)
Access door:	(Optional)
Remote control:	(Standard)
Convection grills built-in and surface-mounted:	(Optional)

SUMMUM 190 F

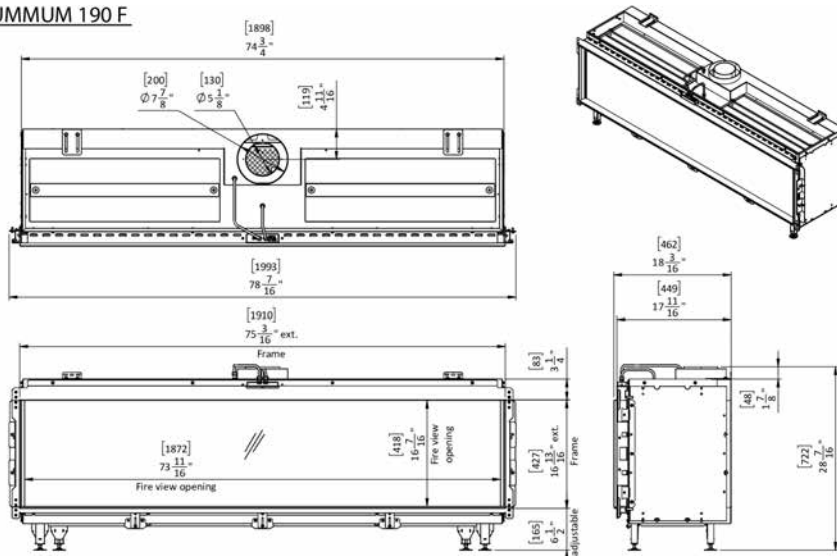



Gasfire

MODORE 240

Multi burner	
Natural gas (min-max):	26,000 - 88,000 BTU
Propane (min-max):	19,500 - 64,800 BTU
Efficiency:	89%
<hr/>	
Energy efficiency class:	A
Venting \varnothing (inch):	5" x 8"
<hr/>	
Black steel:	(Standard)
Black reflective panels:	(Optional)
<hr/>	
Connect to home automation:	(Optional)
Operation via app - wifi kit (ProControl):	(Optional)
Powerfan:	(Optional)
Access door:	(Optional)
Remote control:	(Standard)
Convection grills built-in and surface-mounted:	(Optional)

MODORE 240

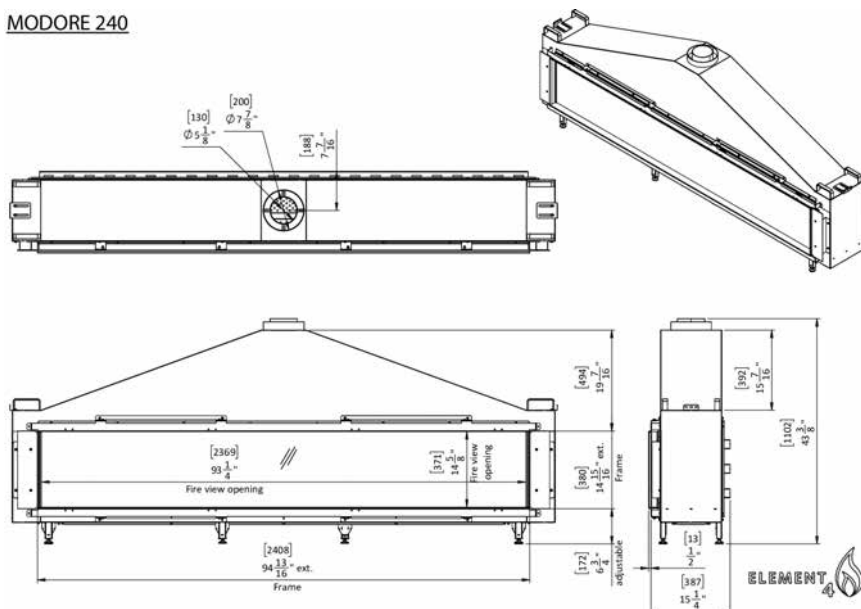



Gasfire

SKY SMALL FRONT

Real Flame Burner	
Natural gas (min-max):	10,132 - 61,301 BTU
Propane (min-max):	8,907 - 42,971 BTU
Efficiency:	89%

Energy efficiency class:	A
Venting \varnothing (inch):	5" x 8"

Black steel:	(Standard)
Black reflective panels:	(Optional)

Connect to home automation:	(Optional)
Operation via app - wifi kit (ProControl):	(Optional)
Powerfan:	(Optional)
Anti-reflective glass:	(Optional)
Access door:	(Optional)
Remote control:	(Standard)
Convection grills built-in and surface-mounted:	(Optional)

SKY SF

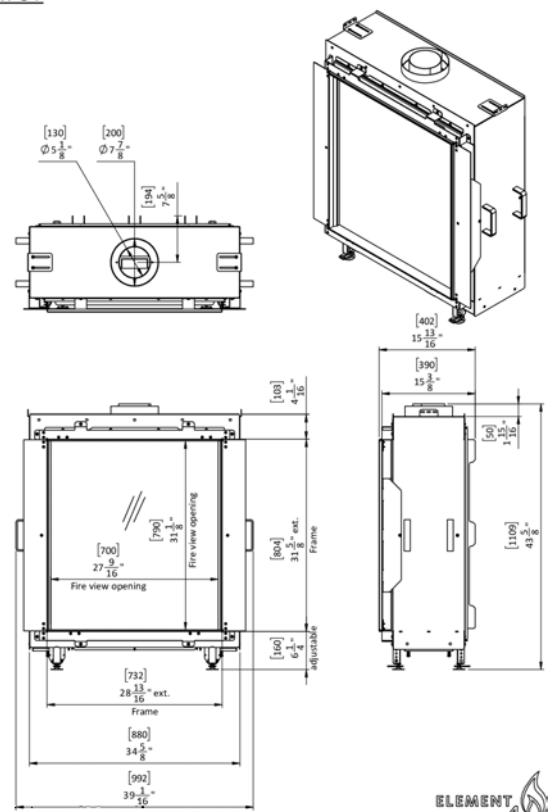



Gasfire

SKY MEDIUM FRONT

Real Flame Burner	
Natural gas (min-max):	10,132 - 61,301 BTU
Propane (min-max):	8,907 - 42,971 BTU
Efficiency:	89%

Energy efficiency class:	A
Venting \varnothing (inch):	5" x 8"

Black steel:	(Standard)
Black reflective panels:	(Optional)

Connect to home automation:	(Optional)
Operation via app - wifi kit (ProControl):	(Optional)
Powerfan:	(Optional)
Anti-reflective glass:	(Optional)
Access door:	(Optional)
Remote control:	(Standard)
Convection grills built-in and surface-mounted:	(Optional)
LED bottom lighting:	(Optional)

SKY MEDIUM F

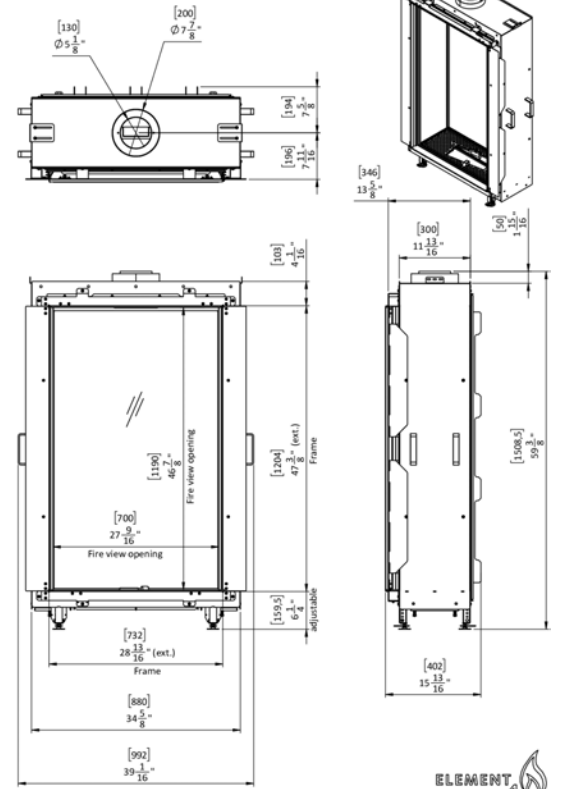



Gasfire

SKY LARGE FRONT

Double burner, Real Flame Burner	
Natural gas (min-max):	17,000 - 44,000 BTU
Propane (min-max):	11,000 - 36,000 BTU
Efficiency:	89%

Energy efficiency class:	A
Venting \varnothing (inch):	5" x 8"

Black steel:	(Standard)
Black reflective panels:	(Optional)

Connect to home automation:	(Optional)
Operation via app - wifi kit (ProControl):	(Optional)
Powerfan:	(Optional)
Anti-reflective glass:	(Optional)
Access door:	(Optional)
Remote control:	(Standard)
Convection grills built-in and surface-mounted:	(Optional)
LED bottom lighting:	(Optional)

SKY LARGE F

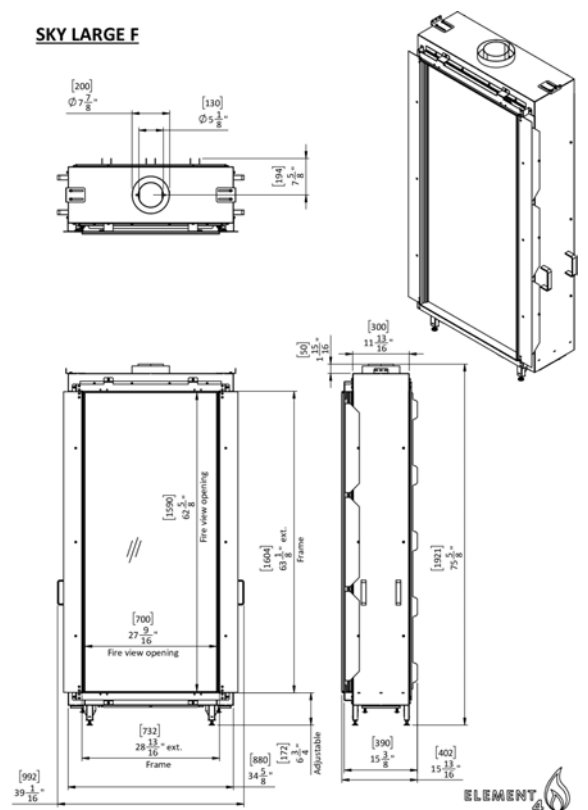



Gasfire

TENORE 140

Double burner	
Natural gas (min-max):	13,650 - 38,200 BTU
Propane (min-max):	11,950 - 34,100 BTU
Efficiency:	90%
<hr/>	
Energy efficiency class:	A
Venting \varnothing (inch):	5" x 8"
<hr/>	
Black steel:	(Standard)
Black reflective panels:	(Optional)
<hr/>	
Connect to home automation:	(Optional)
Operation via app - wifi kit (ProControl):	(Optional)
Powerfan:	(Optional)
Anti-reflective glass:	(Optional)
Access door:	(Optional)
Remote control:	(Standard)
Convection grills built-in and surface-mounted:	(Optional)

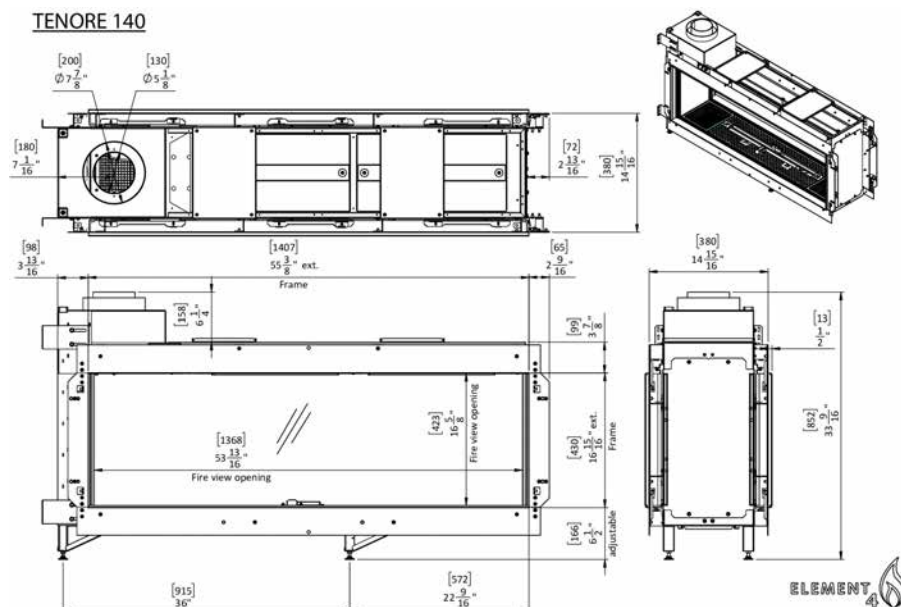



Gasfire

SUMMUM 140 T

Real Flame Burner	
Natural gas (min-max):	20,463 - 81,341 BTU
Propane (min-max):	19,955 - 80,544 BTU
Efficiency:	90%

Energy efficiency class:	A
Venting \varnothing (inch):	5" x 8"

Black steel:	(Standard)
Black reflective panels:	(Optional)

Connect to home automation:	(Optional)
Operation via app - wifi kit (ProControl):	(Optional)
Powerfan:	(Optional)
Anti-reflective glass:	(Optional)
Access door:	(Optional)
Remote control:	(Standard)
Convection grills built-in and surface-mounted:	(Optional)

LED bottom lighting:

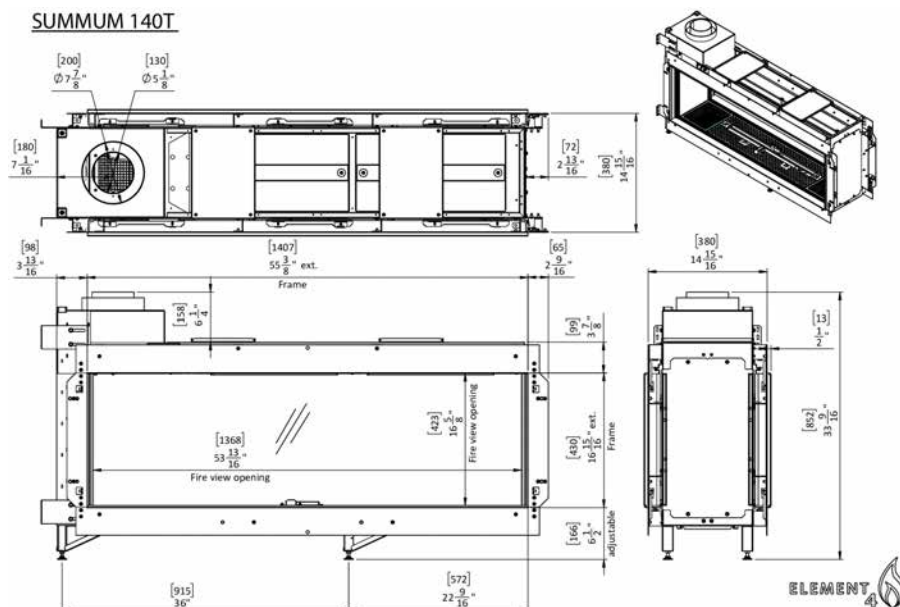

ELEMENT 4



Gasfire

TENORE 240

Multi burner	
Natural gas (min-max):	26,000 - 88,000 BTU
Propane (min-max):	19,500 - 64,800 BTU
Efficiency:	89%

Energy efficiency class:	A
Venting \varnothing (inch):	5" x 8"

Black steel:	(Standard)
Black reflective panels:	(Optional)

Connect to home automation:	(Optional)
Operation via app - wifi kit (ProControl):	(Optional)
Powerfan:	(Optional)
Access door:	(Optional)
Remote control:	(Standard)
Convection grills built-in and surface-mounted:	(Optional)

TENORE 240

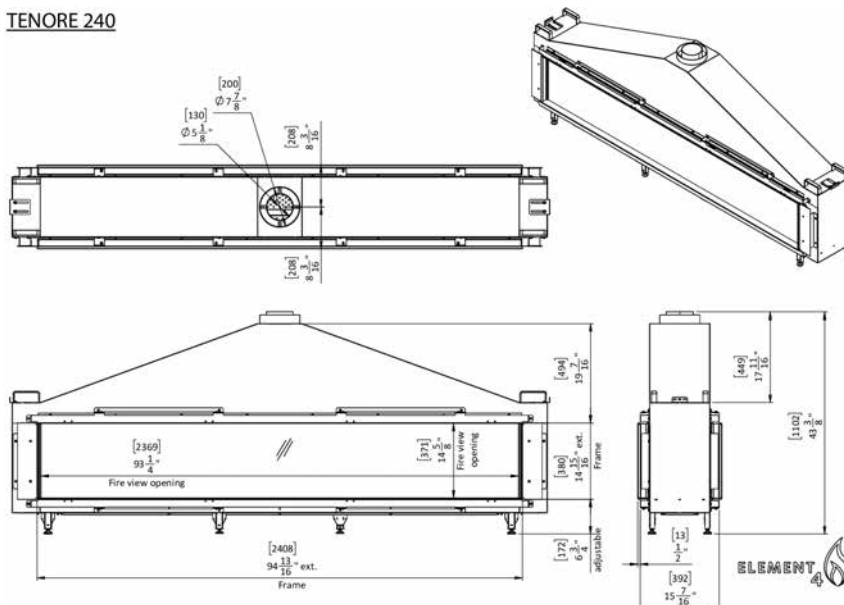



Gasfire

SKY SMALL TUNNEL

Real Flame Burner	
Natural gas (min-max):	10,132 - 61,301 BTU
Propane (min-max):	8,907 - 42,971 BTU
Efficiency:	89%
<hr/>	
Energy efficiency class:	A
Venting ø (inch):	5" x 8"
<hr/>	
Black steel:	(Standard)
Black reflective panels:	(Optional)
<hr/>	
Connect to home automation:	(Optional)
Operation via app - wifi kit (ProControl):	(Optional)
Powerfan:	(Optional)
Anti-reflective glass:	(Optional)
Access door:	(Optional)
Remote control:	(Standard)
Convection grills built-in and surface-mounted:	(Optional)
LED bottom lighting:	(Optional)

SKY ST

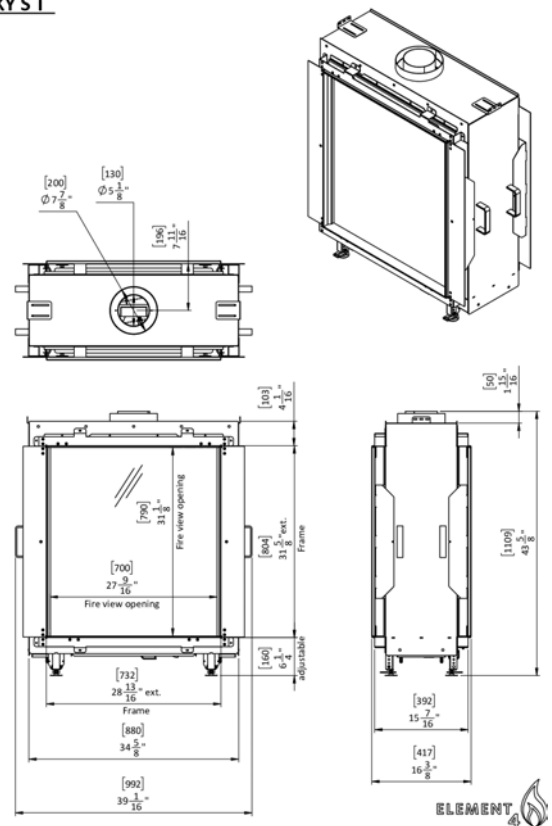

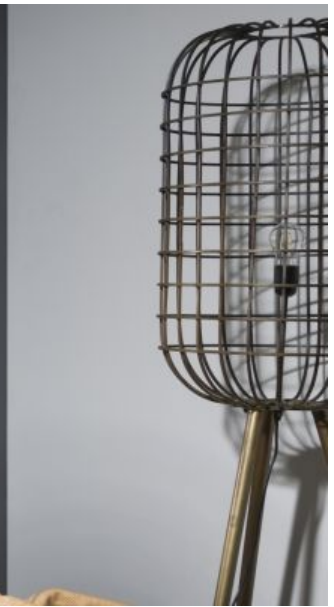

Gasfire

SKY MEDIUM TUNNEL

Real Flame Burner	
Natural gas (min-max):	10,132 - 61,301 BTU
Propane (min-max):	8,907 - 42,971 BTU
Efficiency:	89%

Energy efficiency class:	A
Venting \varnothing (inch):	5" x 8"

Black steel:	(Standard)
Black reflective panels:	(Optional)

Connect to home automation:	(Optional)
Operation via app - wifi kit (ProControl):	(Optional)
Powerfan:	(Optional)
Anti-reflective glass:	(Optional)
Access door:	(Optional)
Remote control:	(Standard)
Convection grills built-in and surface-mounted:	(Optional)
LED bottom lighting:	(Optional)

SKY M T

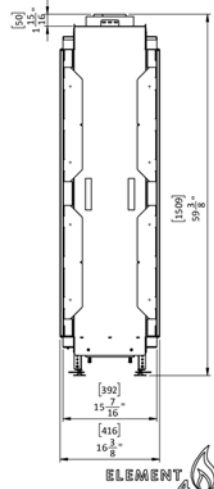
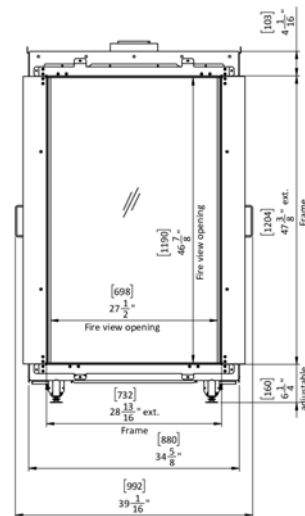
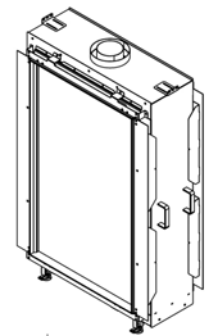
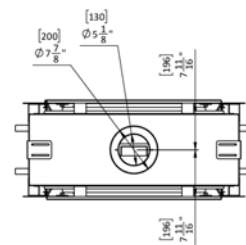



Gasfire

SKY LARGE TUNNEL

Double burner, Real Flame Burner	
Natural gas (min-max):	17,000 - 44,000 BTU
Propane (min-max):	11,000 - 36,000 BTU
Efficiency:	89%
<hr/>	
Energy efficiency class:	A
Venting \varnothing (inch):	5" x 8"
<hr/>	
Black steel:	(Standard)
Black reflective panels:	(Optional)
<hr/>	
Connect to home automation:	(Optional)
Operation via app - wifi kit (ProControl):	(Optional)
Powerfan:	(Optional)
Anti-reflective glass:	(Optional)
Access door:	(Optional)
Remote control:	(Standard)
Convection grills built-in and surface-mounted:	(Optional)
LED bottom lighting:	(Optional)

SKY LT

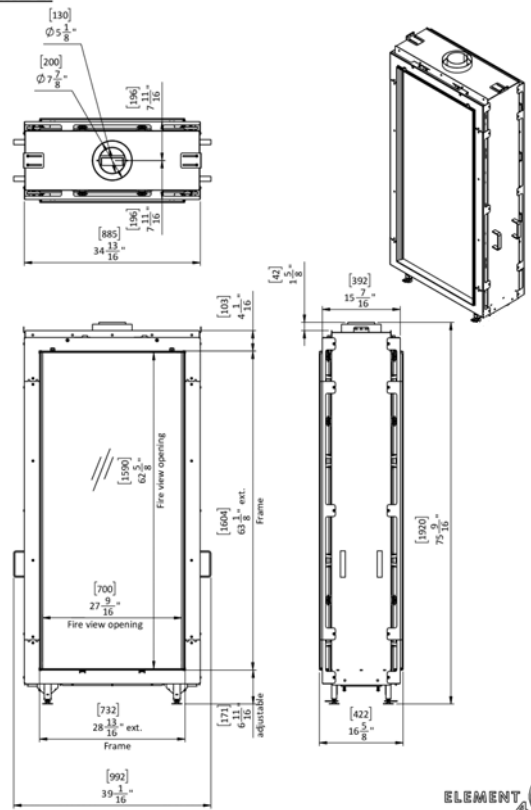



Gasfire

SUMMUM 70 3/S

Real Flame Burner	
Natural gas (min-max):	13,375 - 33,439 BTU
Propane (min-max):	10,509 - 26,273 BTU
Efficiency:	88%

Energy efficiency class:	B
Venting \varnothing (inch):	5" x 8"

Black steel:	(Standard)
Black reflective panels:	(Optional)

Connect to home automation:	(Optional)
Operation via app - wifi kit (ProControl):	(Optional)
Powerfan:	(Optional)
Anti-reflective glass:	(Optional)
Access door:	(Optional)
Remote control:	(Standard)
Convection grills built-in and surface-mounted:	(Optional)

Summum 70 3S

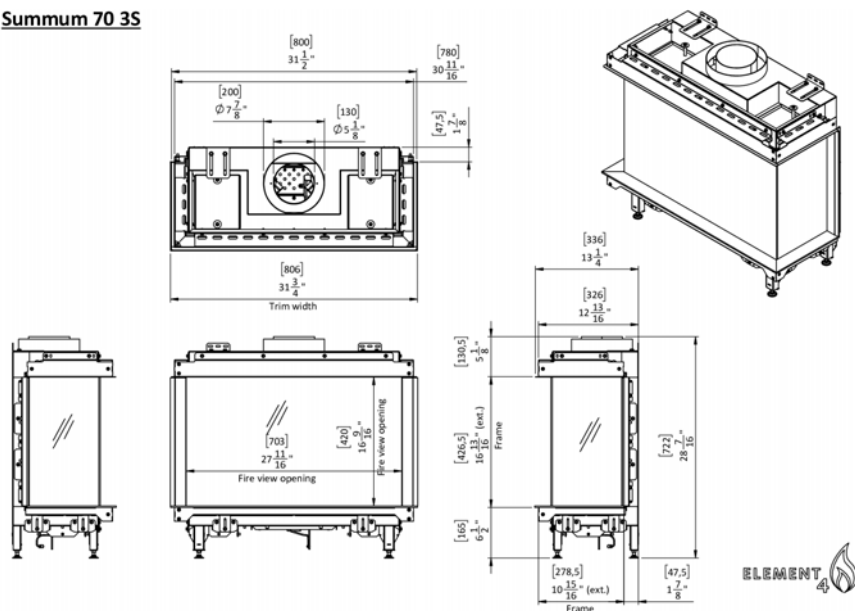



Gasfire

TRISORE 100

Single burner	
Natural gas (min-max):	17,050 - 36,200 BTU
Propane (min-max):	13,650 - 32,400 BTU
Efficiency:	83%
<hr/>	
Energy efficiency class:	B
Venting \varnothing (inch):	5" x 8"
<hr/>	
Black steel:	(Standard)
Black reflective panels:	(Optional)
<hr/>	
Connect to home automation:	(Optional)
Operation via app - wifi kit (ProControl):	(Optional)
Powerfan:	(Optional)
Anti-reflective glass:	(Optional)
Access door:	(Optional)
Remote control:	(Standard)
Convection grills built-in and surface-mounted:	(Optional)

Trisore 100

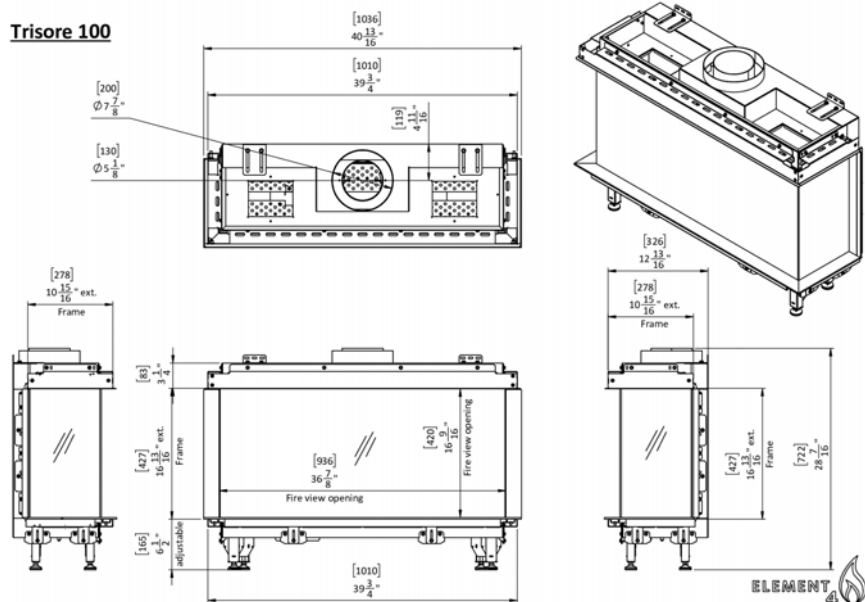



Gasfire

SUMMUM 100 3/S

Real Flame Burner	
Natural gas (min-max):	13,000 - 50,000 BTU
Propane (min-max):	9,000 - 45,000 BTU
Efficiency:	89%
<hr/>	
Energy efficiency class:	A
Venting \varnothing (inch):	5" x 8"
<hr/>	
Black steel:	(Standard)
Black reflective panels:	(Optional)
<hr/>	
Connect to home automation:	(Optional)
Operation via app - wifi kit (ProControl):	(Optional)
Powerfan:	(Optional)
Anti-reflective glass:	(Optional)
Access door:	(Optional)
Remote control:	(Standard)
Convection grills built-in and surface-mounted:	(Optional)

SUMMUM 100 3S

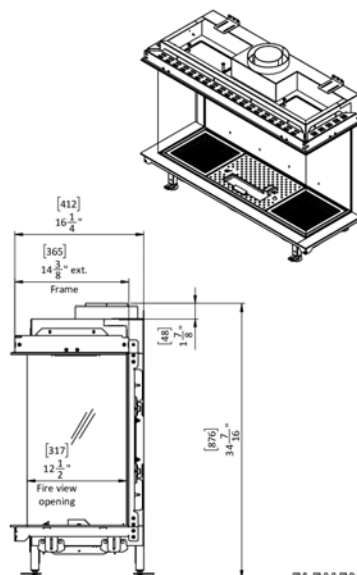
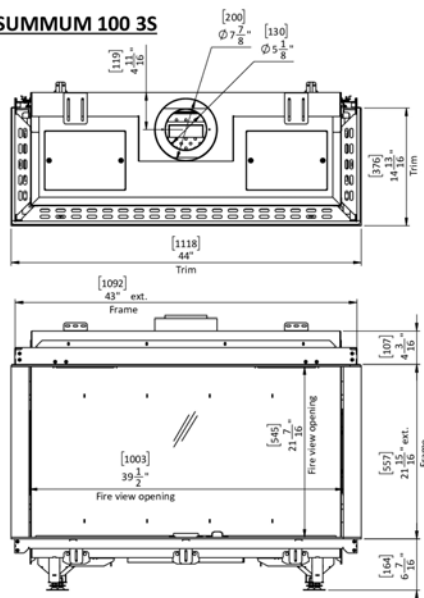



Gasfire

TRISORE 140

Double burner	
Natural gas (min-max):	13,650 - 38,200 BTU
Propane (min-max):	11,950 - 34,100 BTU
Efficiency:	90%

Energy efficiency class:	A
Venting \varnothing (inch):	5" x 8"

Black steel:	(Standard)
Black reflective panels:	(Optional)

Connect to home automation:	(Optional)
Operation via app - wifi kit (ProControl):	(Optional)
Powerfan:	(Optional)
Anti-reflective glass:	(Optional)
Access door:	(Optional)
Remote control:	(Standard)
Convection grills built-in and surface-mounted:	(Optional)

TRISORE 140

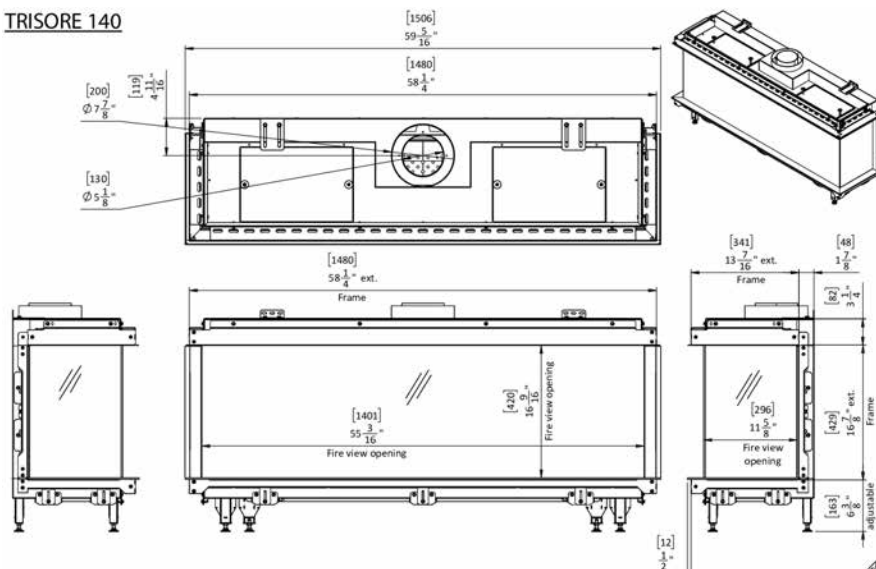



Gasfire

SUMMUM 140 3S

Real Flame Burner	
Natural gas (min-max):	20,463 - 81,341 BTU
Propane (min-max):	19,955 - 80,544 BTU
Efficiency:	90%

Energy efficiency class:	A
Venting \varnothing (inch):	5" x 8"

Black steel:	(Standard)
Black reflective panels:	(Optional)

Connect to home automation:	(Optional)
Operation via app - wifi kit (ProControl):	(Optional)
Powerfan:	(Optional)
Anti-reflective glass:	(Optional)
Access door:	(Optional)
Remote control:	(Standard)
Convection grills built-in and surface-mounted:	(Optional)

SUMMUM 140 3S

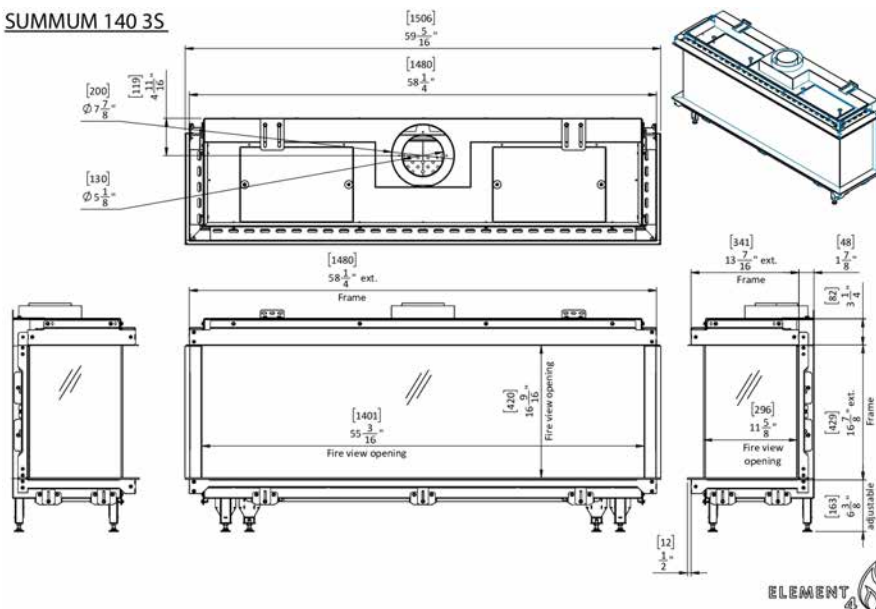



Gasfire

SUMMUM 190 3S

Real Flame Burner L LED	
Natural gas (min-max):	20,463 - 81,341 BTU
Propane (min-max):	19,955 - 80,544 BTU
Efficiency:	89%

Energy efficiency class:	A
Venting ø (inch):	5" x 8"

Black steel:	(Standard)
Black reflective panels:	(Optional)

Connect to home automation:	(Optional)
Operation via app - wifi kit (ProControl):	(Optional)
Powerfan:	(Optional)
Anti-reflective glass:	(Optional)
Access door:	(Optional)
Remote control:	(Standard)
Convection grills built-in and surface-mounted:	(Optional)

SUMMUM 190 3S

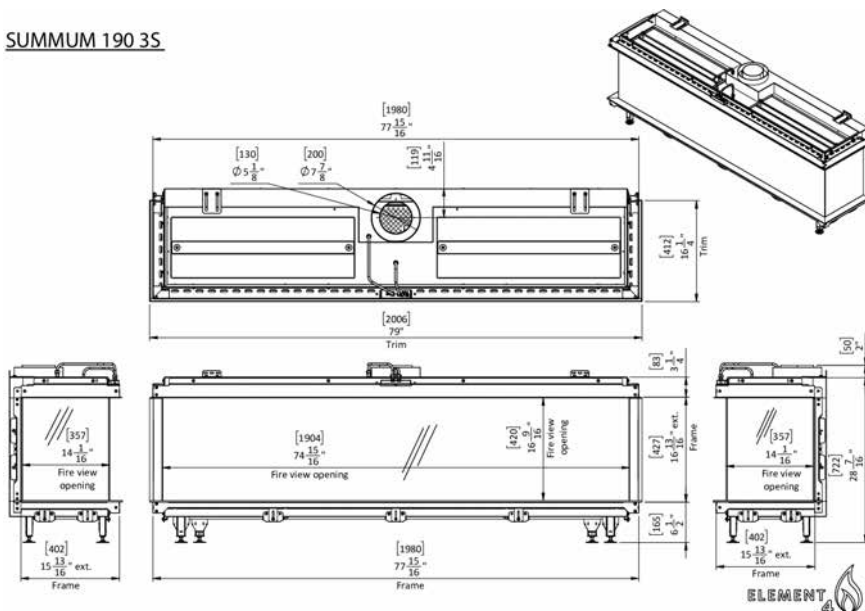



Gasfire

SUMMUM 70 C

Real Flame Burner	
Natural gas (min-max):	13,375 - 33,439 BTU
Propane (min-max):	10,509 - 26,273 BTU
Efficiency:	88%

Energy efficiency class:	B
Venting ø (inch):	5" x 8"

Black steel:	(Standard)
Black reflective panels:	(Optional)

Connect to home automation:	(Optional)
Operation via app - wifi kit (ProControl):	(Optional)
Powerfan:	(Optional)
Anti-reflective glass:	(Optional)
Access door:	(Optional)
Remote control:	(Standard)
Convection grills built-in and surface-mounted:	(Optional)

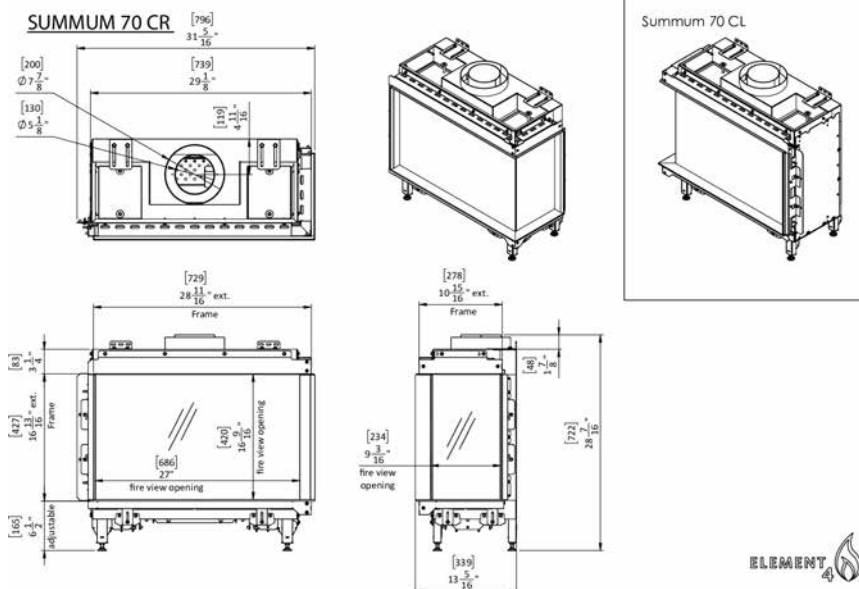



Gasfire

BIDORE 100

Single burner	
Natural gas (min-max):	17,050 - 36,200 BTU
Propane (min-max):	13,650 - 32,400 BTU
Efficiency:	83%

Energy efficiency class:	B
Venting \varnothing (inch):	5" x 8"

Black steel:	(Standard)
Black reflective panels:	(Optional)

Connect to home automation:	(Optional)
Operation via app - wifi kit (ProControl):	(Optional)
Powerfan:	(Optional)
Anti-reflective glass:	(Optional)
Access door:	(Optional)
Remote control:	(Standard)
Convection grills built-in and surface-mounted:	(Optional)

Bidore 100 CL

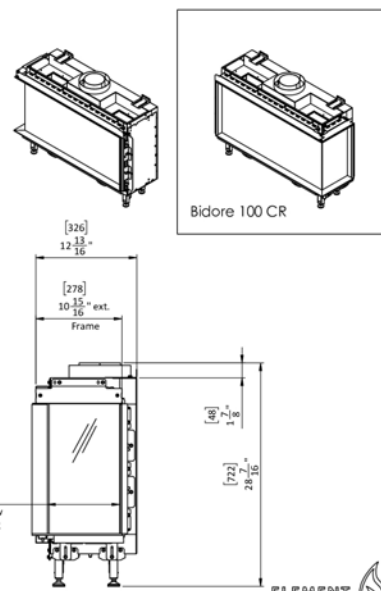
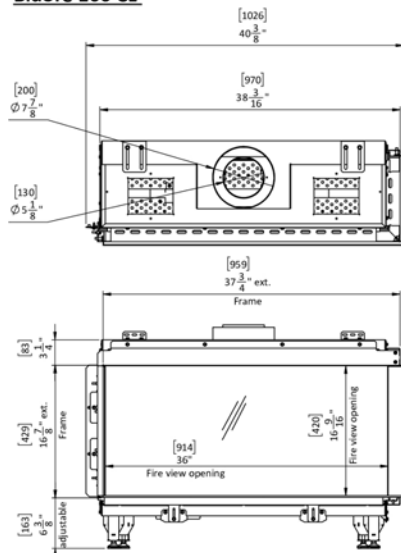



Gasfire

SUMMUM 100 C

Real Flame Burner	
Natural gas (min-max):	13,000 - 50,000 BTU
Propane (min-max):	9,000 - 45,000 BTU
Efficiency:	89%
<hr/>	
Energy efficiency class:	A
Venting \varnothing (inch):	5" x 8"
<hr/>	
Black steel:	(Standard)
Black reflective panels:	(Optional)
<hr/>	
Connect to home automation:	(Optional)
Operation via app - wifi kit (ProControl):	(Optional)
Powerfan:	(Optional)
Anti-reflective glass:	(Optional)
Access door:	(Optional)
Remote control:	(Standard)
Convection grills built-in and surface-mounted:	(Optional)

SUMMUM 100 CR

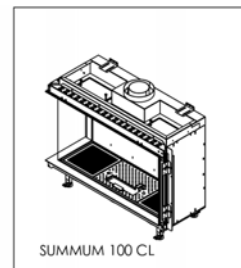
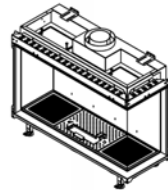
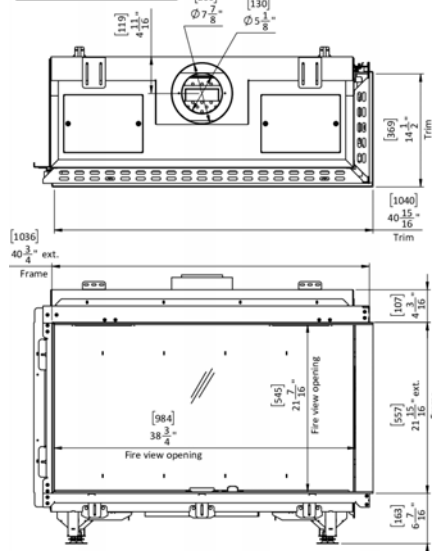

SUMMUM 100 CL

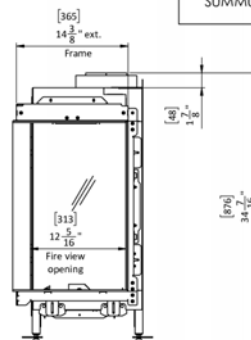



Gasfire

BIDORE 140

Double burner	
Natural gas (min-max):	13,650 - 38,200 BTU
Propane (min-max):	11,950 - 34,100 BTU
Efficiency:	90%

Energy efficiency class:	A
Venting \varnothing (inch):	5" x 8"

Black steel:	(Standard)
Black reflective panels:	(Optional)

Connect to home automation:	(Optional)
Operation via app - wifi kit (ProControl):	(Optional)
Powerfan:	(Optional)
Anti-reflective glass:	(Optional)
Access door:	(Optional)
Remote control:	(Standard)
Convection grills built-in and surface-mounted:	(Optional)

Bidore 140 R

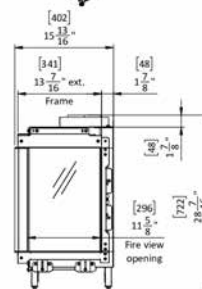
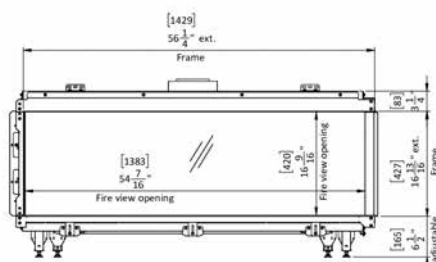
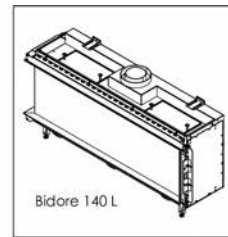
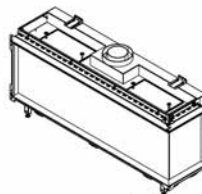
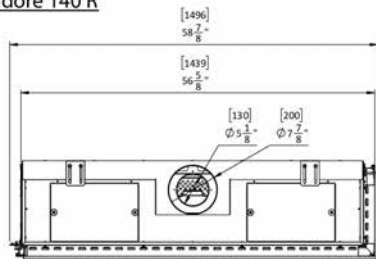



Gasfire

SUMMUM 140 C

Real Flame Burner L LED	
Natural gas (min-max):	20,463 - 81,341 BTU
Propane (min-max):	19,955 - 80,544 BTU
Efficiency:	90%
<hr/>	
Energy efficiency class:	A
Venting \varnothing (inch):	5" x 8"
<hr/>	
Black steel:	(Standard)
Black reflective panels:	(Optional)
<hr/>	
Connect to home automation:	(Optional)
Operation via app - wifi kit (ProControl):	(Optional)
Powerfan:	(Optional)
Anti-reflective glass:	(Optional)
Access door:	(Optional)
Remote control:	(Standard)
Convection grills built-in and surface-mounted:	(Optional)

SUMMUM 140 CR

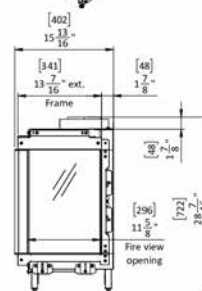
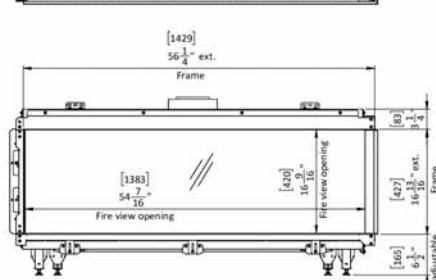
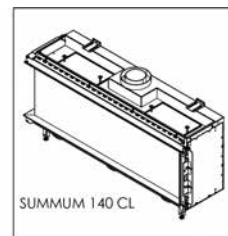
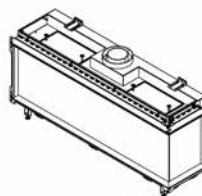
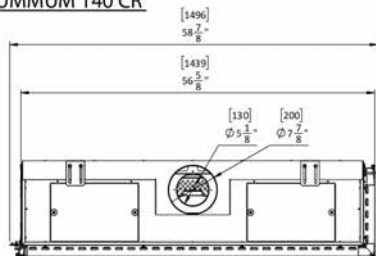



Gasfire

SUMMUM 190 C

Real Flame Burner	
Natural gas (min-max):	20,463 - 81,341 BTU
Propane (min-max):	19,955 - 80,544 BTU
Efficiency:	89%

Energy efficiency class:	A
Venting \varnothing (inch):	5" x 8"

Black steel:	(Standard)
Black reflective panels:	(Optional)

Connect to home automation:	(Optional)
Operation via app - wifi kit (ProControl):	(Optional)
Powerfan:	(Optional)
Anti-reflective glass:	(Optional)
Access door:	(Optional)
Remote control:	(Standard)
Convection grills built-in and surface-mounted:	(Optional)

SUMMUM 190 CR

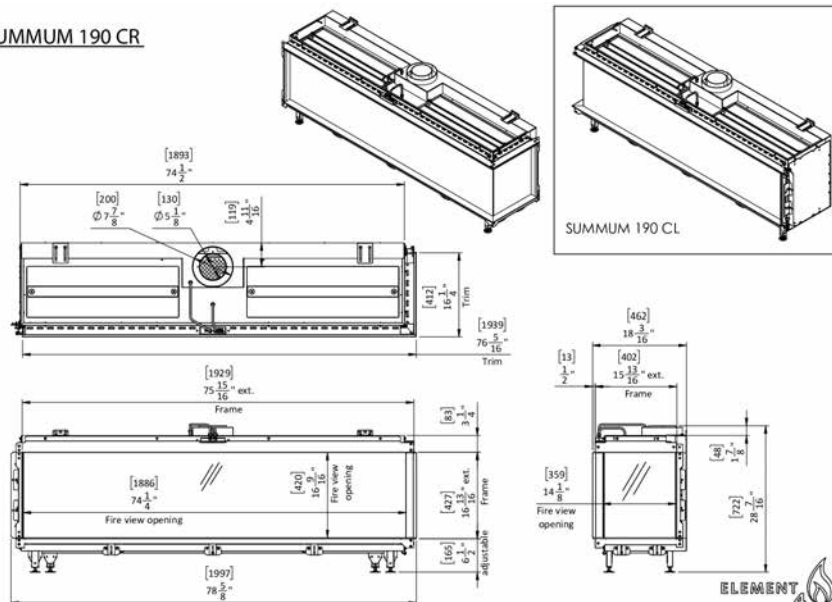



Gasfire

LUCIUS 140

Double burner	
Natural gas (min-max):	13,650 - 38,200 BTU
Propane (min-max):	11,950 - 34,100 BTU
Efficiency:	90%

Energy efficiency class:	A
Venting \varnothing (inch):	5" x 8"

Black steel:	(Standard)
Black reflective panels:	(Optional)

Connect to home automation:	(Optional)
Operation via app - wifi kit (ProControl):	(Optional)
Powerfan:	(Optional)
Anti-reflective glass:	(Optional)
Access door:	(Optional)
Remote control:	(Standard)
Convection grills built-in and surface-mounted:	(Optional)

Lucius 140

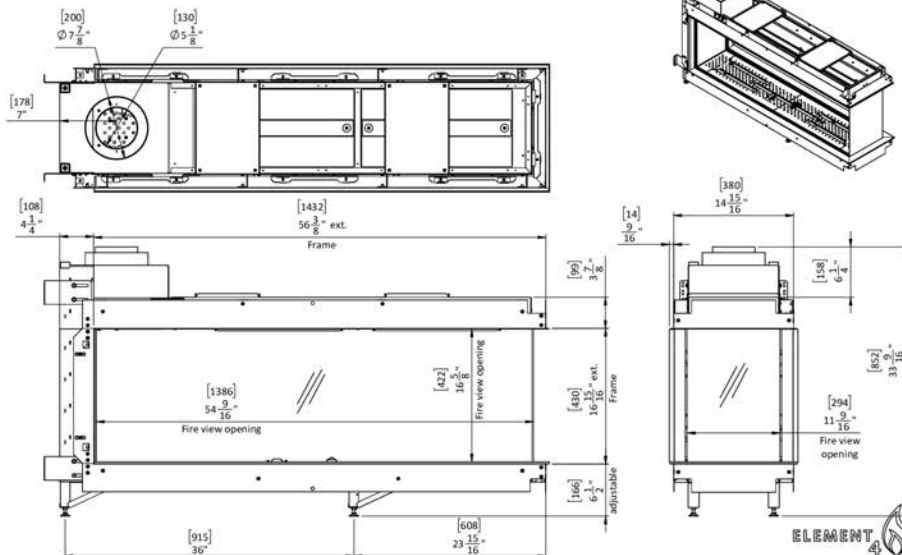



Gasfire

SUMMUM 140 RD

Real Flame Burner L LED	
Natural gas (min-max):	20,463 - 81,341 BTU
Propane (min-max):	19,955 - 80,544 BTU
Efficiency:	90%

Energy efficiency class:	A
Venting ø (inch):	5" x 8"

Black steel:	(Standard)
Black reflective panels:	(Optional)

Connect to home automation:	(Optional)
Operation via app - wifi kit (ProControl):	(Optional)
Powerfan:	(Optional)
Anti-reflective glass:	(Optional)
Access door:	(Optional)
Remote control:	(Standard)
Convection grills built-in and surface-mounted:	(Optional)

SUMMUM 140 RD

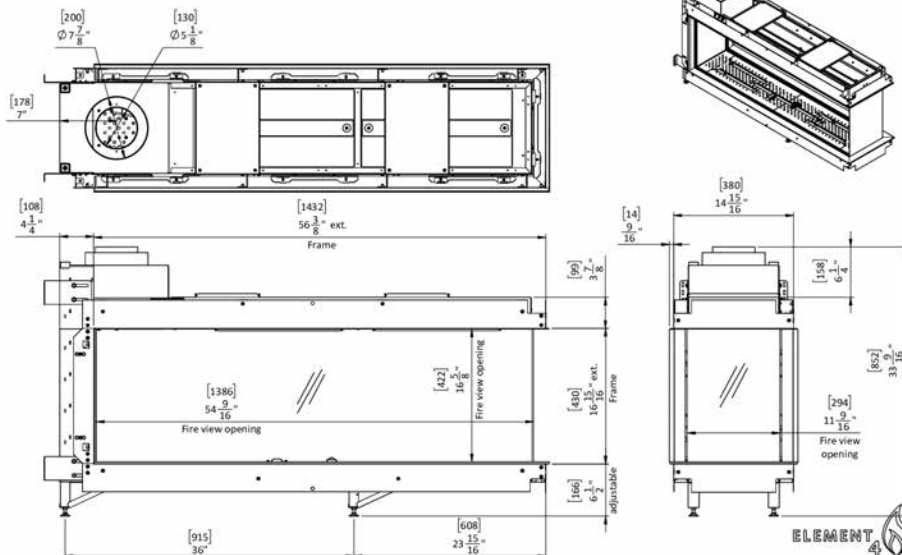



Gasfire

SKY SMALL ROOMDIVIDER

Real Flame Burner	
Natural gas (min-max):	10,132 - 61,301 BTU
Propane (min-max):	8,907 - 42,971 BTU
Efficiency:	89%
<hr/>	
Energy efficiency class:	A
Venting \varnothing (inch):	5" x 8"
<hr/>	
Black steel:	(Standard)
Black reflective panels:	(Optional)
<hr/>	
Connect to home automation:	(Optional)
Operation via app - wifi kit (ProControl):	(Optional)
Powerfan:	(Optional)
Anti-reflective glass:	(Optional)
Access door:	(Optional)
Remote control:	(Standard)
Convection grills built-in and surface-mounted:	(Optional)
LED bottom lighting:	(Optional)

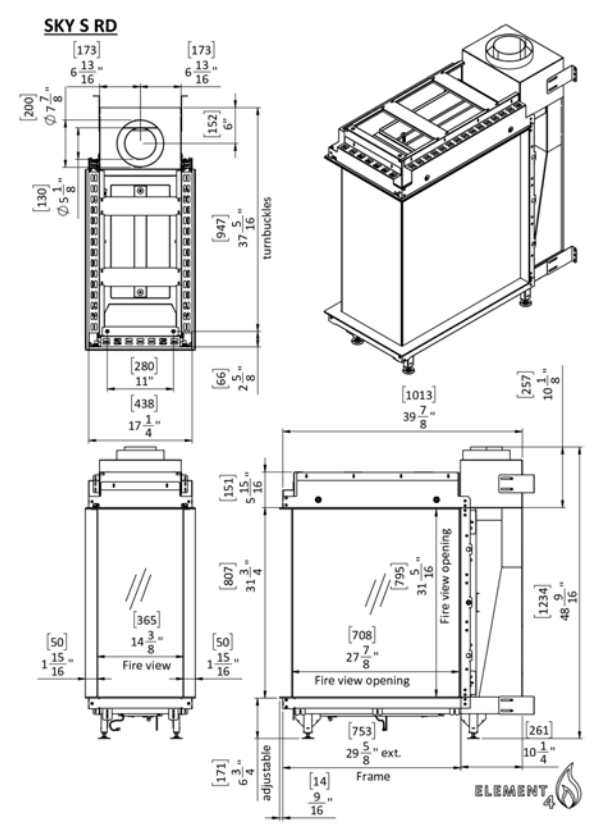



Gasfire

SKY MEDIUM ROOMDIVIDER

Real Flame Burner	
Natural gas (min-max):	10,132 - 61,301 BTU
Propane (min-max):	8,907 - 42,971 BTU
Efficiency:	89%
<hr/>	
Energy efficiency class:	A
Venting \varnothing (inch):	5" x 8"
<hr/>	
Black steel:	(Standard)
Black reflective panels:	(Optional)
<hr/>	
Connect to home automation:	(Optional)
Operation via app - wifi kit (ProControl):	(Optional)
Powerfan:	(Optional)
Anti-reflective glass:	(Optional)
Access door:	(Optional)
Remote control:	(Standard)
Convection grills built-in and surface-mounted:	(Optional)
LED bottom lighting:	(Optional)

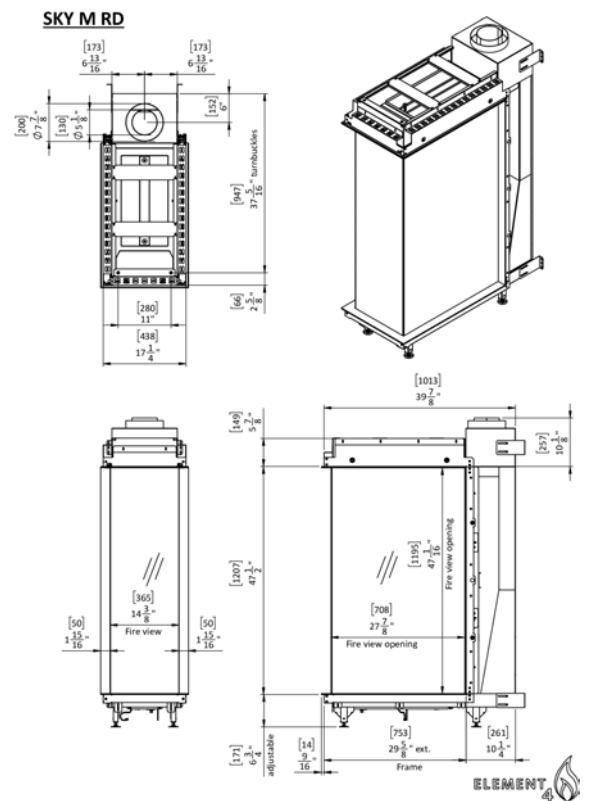

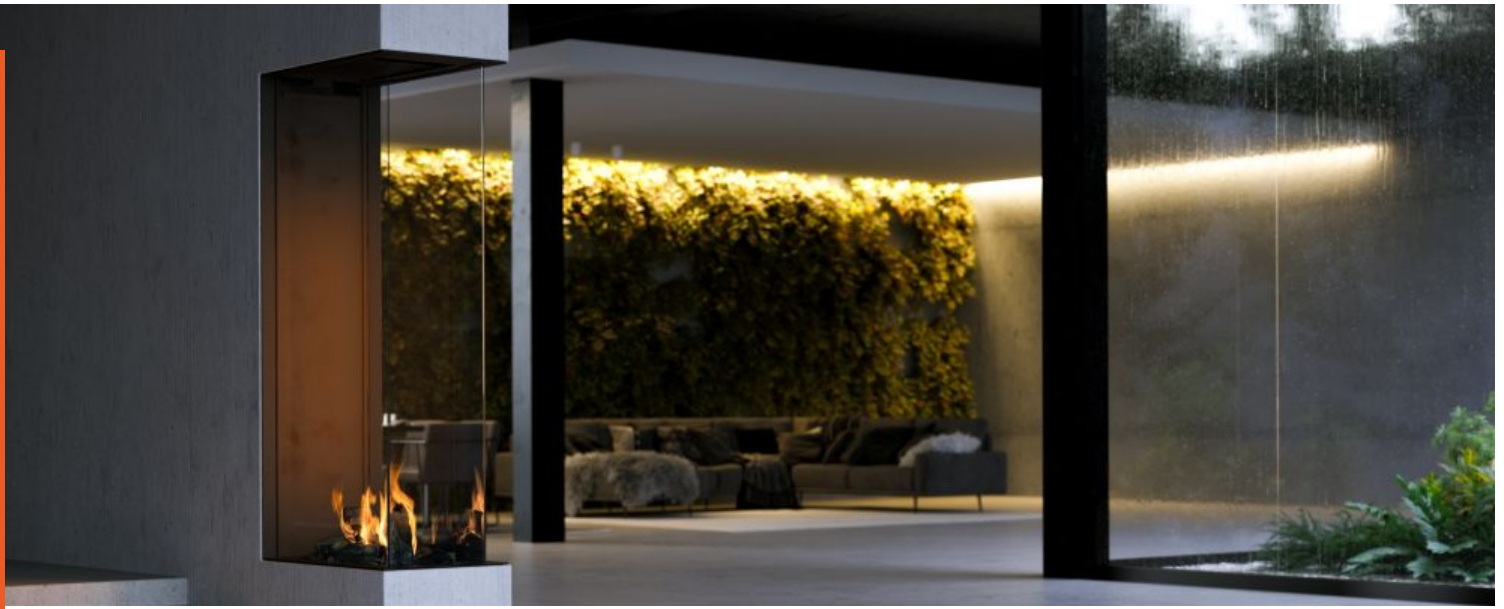

Gasfire

SKY LARGE ROOMDIVIDER

Real Flame Burner
 Natural gas (min-max): 10,132 - 61,301 BTU
 Propane (min-max): 8,907 - 42,971 BTU
 Efficiency: 89%

Energy efficiency class: A
 Venting \varnothing (inch): 5" x 8"

Black steel: (Standard)
 Black reflective panels: (Optional)

Connect to home automation: (Optional)
 Operation via app - wifi kit (ProControl): (Optional)
 Powerfan: (Optional)
 Anti-reflective glass: (Optional)
 Access door: (Optional)
 Remote control: (Standard)
 Convection grills built-in and surface-mounted: (Optional)
 LED bottom lighting: (Optional)

SKY L RD

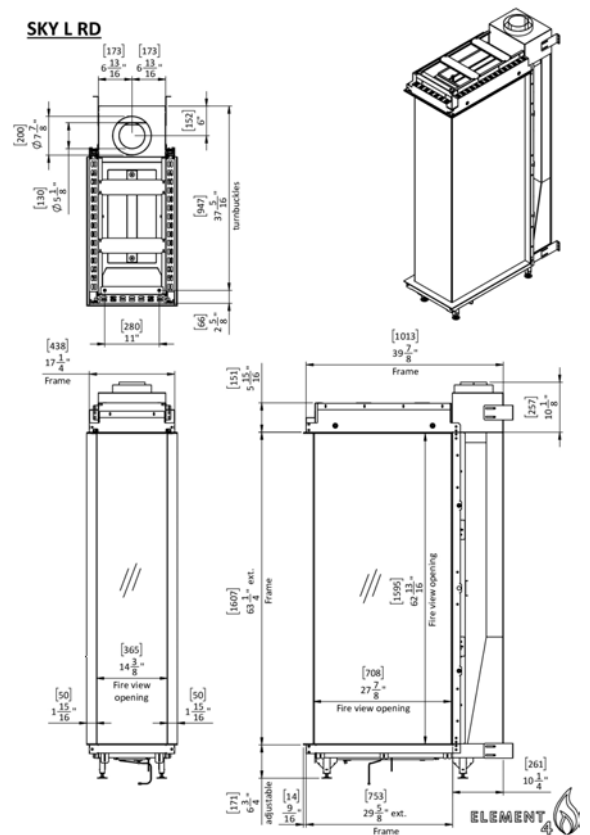



Gasfire

SUMMUM 140 4/S

Real Flame Burner	
Natural gas (min-max):	20,463 - 81,341 BTU
Propane (min-max):	19,955 - 80,544 BTU
Efficiency:	90%
<hr/>	
Energy efficiency class:	A
Venting ø (inch):	5" x 8"
<hr/>	
Connect to home automation:	(Optional)
Operation via app - wifi kit (ProControl):	(Optional)
Powerfan:	(Optional)
Access door:	(Optional)
Remote control:	(Standard)
Convection grills built-in and surface-mounted:	(Optional)

SUMMUM 140 4S

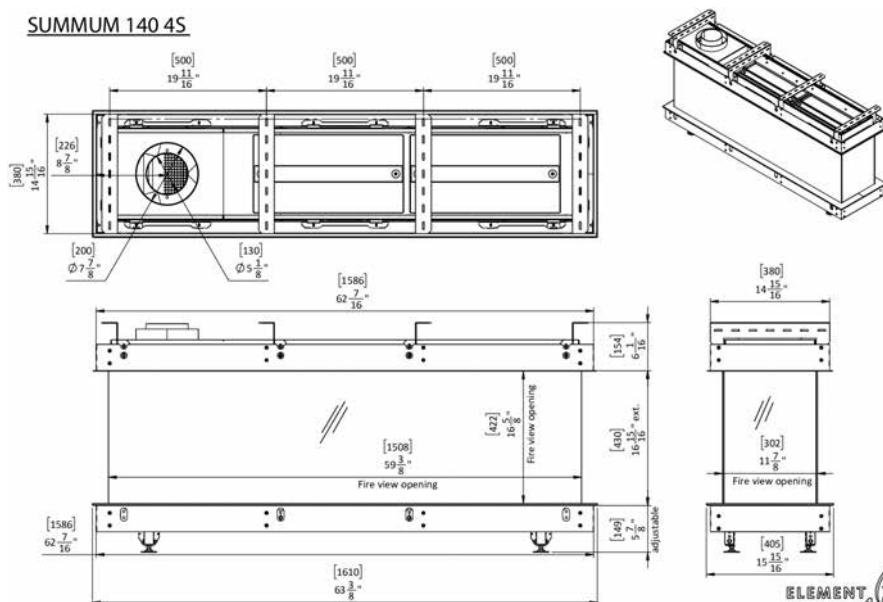



Gasfire

OVATION

Real Flame Burner	
Natural gas (min-max):	5,800-22,520 BTU
Propane (min-max):	5,459-23,202 BTU
Efficiency:	90%

Energy efficiency class:	A
Venting ø (inch):	4" x 6"

Black steel:	(Standard)
Black reflective panels:	(Optional)

Connect to home automation:	(Optional)
Operation via app - wifi kit (ProControl):	(Optional)
Powerfan:	(Optional)
Remote control:	(Standard)

OVATION

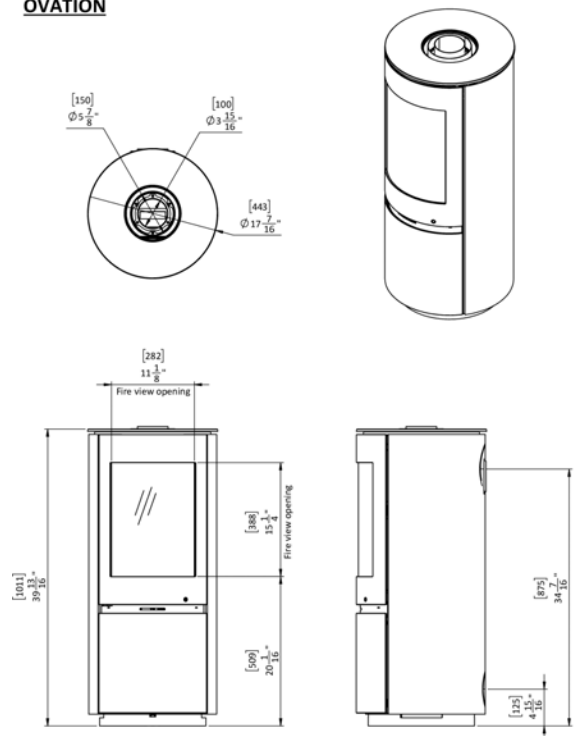



Gasfire

MODORE 140 OUTDOOR

Quad burner	
Natural gas (min-max):	13,650 - 38,200 BTU
Propane (min-max):	11,950 - 34,100 BTU
Efficiency:	90%
<hr/>	
Energy efficiency class:	A
Venting \varnothing (inch):	5" x 8"
<hr/>	
Black steel:	(Standard)
Black reflective panels:	(Optional)
<hr/>	
Connect to home automation:	(Optional)
Operation via app - wifi kit (ProControl):	(Optional)
Powerfan:	(Optional)
Anti-reflective glass:	(Optional)
Access door:	(Optional)
Remote control:	(Standard)
Convection grills built-in and surface-mounted:	(Optional)

MODORE 140

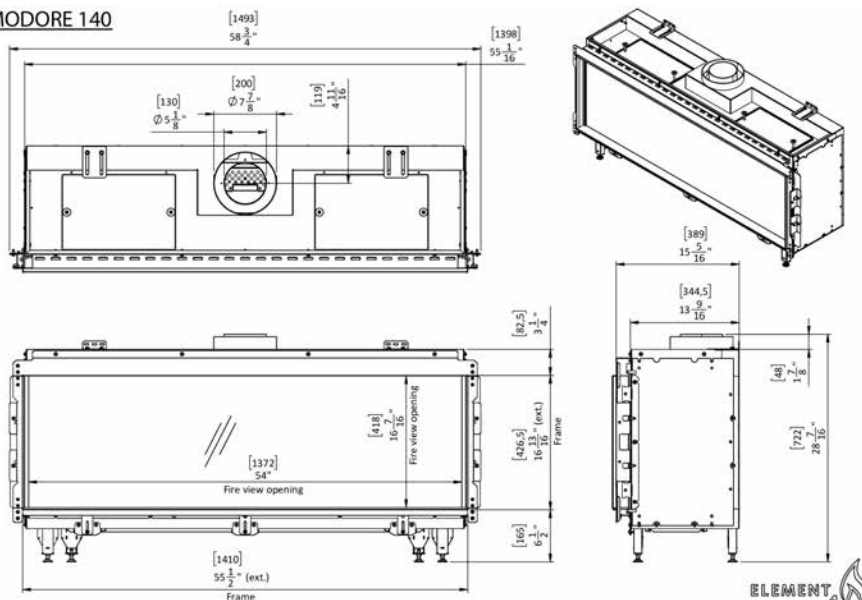



Gasfire

SKY SMALL FRONT OUTDOOR

Real Flame Burner	
Natural gas (min-max):	17,000 - 44,000 BTU
Propane (min-max):	11,000 - 36,000 BTU
Efficiency:	89%

Energy efficiency class:	A
Venting \varnothing (inch):	5" x 8"

Black steel:	(Standard)
Black reflective panels:	(Optional)

Connect to home automation:	(Optional)
Operation via app - wifi kit (ProControl):	(Optional)
Powerfan:	(Optional)
Anti-reflective glass:	(Optional)
Access door:	(Optional)
Remote control:	(Standard)
Convection grills built-in and surface-mounted:	(Optional)
LED bottom lighting:	(Optional)

SKY SF

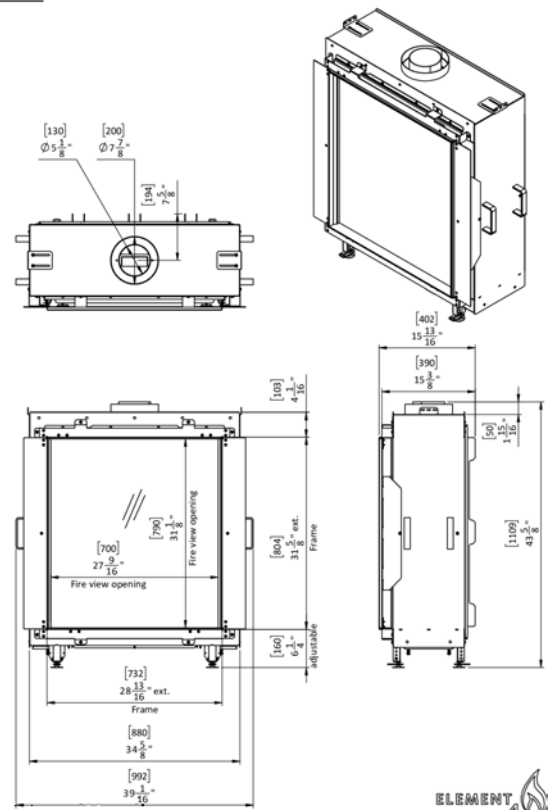



Gasfire

SKY MEDIUM FRONT OUTDOOR

Real Flame Burner	
Natural gas (min-max):	17,000 - 44,000 BTU
Propane (min-max):	11,000 - 36,000 BTU
Efficiency:	89%

Energy efficiency class:	A
Venting \varnothing (inch):	5" x 8"

Black steel:	(Standard)
Black reflective panels:	(Optional)

Connect to home automation:	(Optional)
Operation via app - wifi kit (ProControl):	(Optional)
Powerfan:	(Optional)
Anti-reflective glass:	(Optional)
Access door:	(Optional)
Remote control:	(Standard)
Convection grills built-in and surface-mounted:	(Optional)
LED bottom lighting:	(Optional)

SKY MEDIUM F

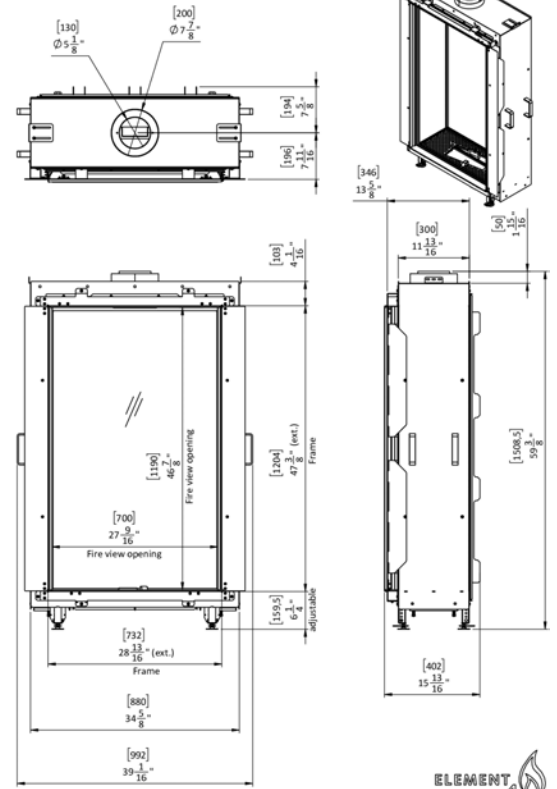



Gasfire

SKY LARGE FRONT OUTDOOR

Double burner, Real Flame Burner

Natural gas (min-max): 17,000 - 44,000 BTU

Propane (min-max): 11,000 - 36,000 BTU

Efficiency: 86%

Energy efficiency class: A

Venting \varnothing (inch): 5" x 8"

Black steel: (Standard)

Black reflective panels: (Optional)

Connect to home automation: (Optional)

Operation via app - wifi kit (ProControl): (Optional)

Powerfan: (Optional)

Anti-reflective glass: (Optional)

Access door: (Optional)

Remote control: (Standard)

Convection grills built-in and surface-mounted: (Optional)

LED bottom lighting: (Optional)

SKY LARGE F

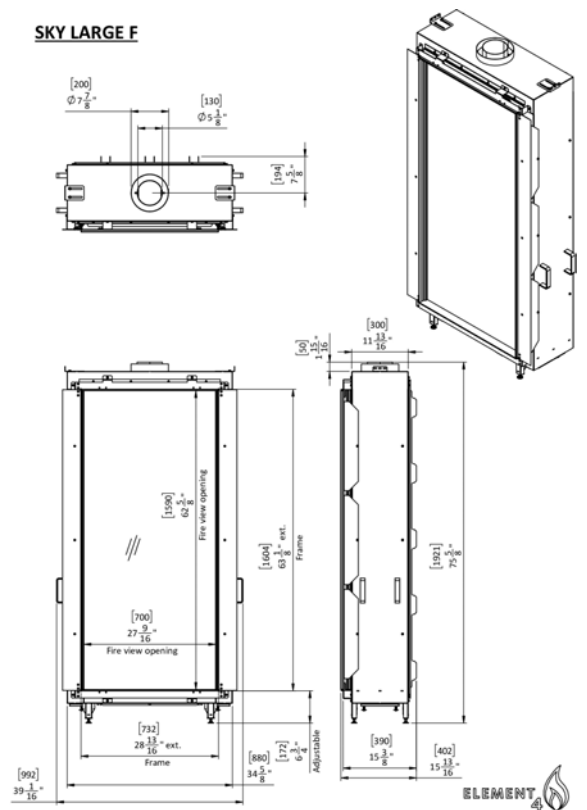



Gasfire

SKY SMALL TUNNEL OUTDOOR

Real Flame Burner	
Natural gas (min-max):	17,000 - 44,000 BTU
Propane (min-max):	11,000 - 36,000 BTU
Efficiency:	89%
<hr/>	
Energy efficiency class:	A
Venting \varnothing (inch):	5" x 8"
<hr/>	
Black steel:	(Standard)
Black reflective panels:	(Optional)
<hr/>	
Connect to home automation:	(Optional)
Operation via app - wifi kit (ProControl):	(Optional)
Powerfan:	(Optional)
Anti-reflective glass:	(Optional)
Access door:	(Optional)
Remote control:	(Standard)
Convection grills built-in and surface-mounted:	(Optional)
LED bottom lighting:	(Optional)

SKY ST

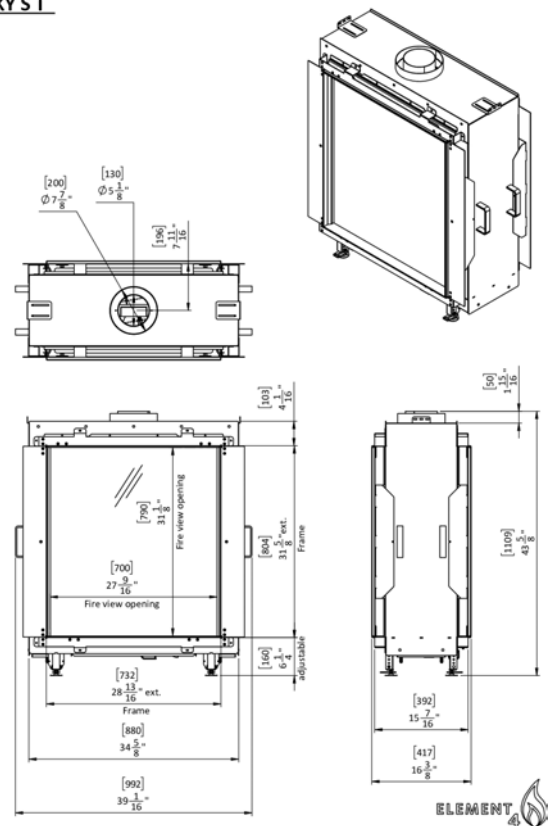



Gasfire

SKY MEDIUM TUNNEL OUTDOOR

Real Flame Burner	
Natural gas (min-max):	17,000 - 44,000 BTU
Propane (min-max):	11,000 - 36,000 BTU
Efficiency:	89%
Energy efficiency class:	A
Venting \varnothing (inch):	5" x 8"
Black steel:	(Standard)
Black reflective panels:	(Optional)
Connect to home automation:	(Optional)
Operation via app - wifi kit (ProControl):	(Optional)
Powerfan:	(Optional)
Anti-reflective glass:	(Optional)
Access door:	(Optional)
Remote control:	(Standard)
Convection grills built-in and surface-mounted:	(Optional)
LED bottom lighting:	(Optional)

SKY M T

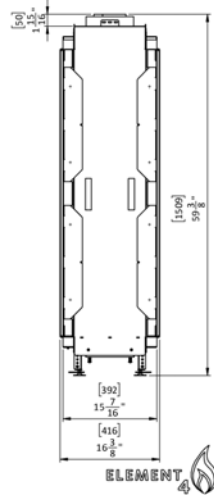
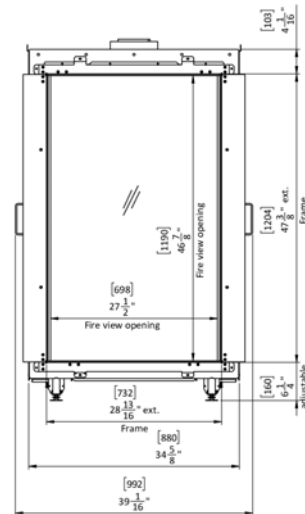
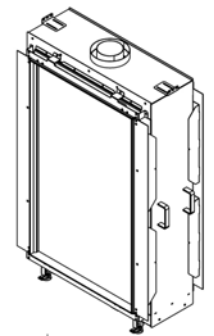
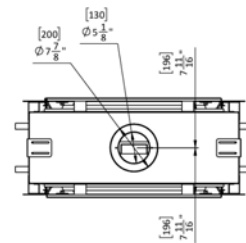



Gasfire

SKY LARGE TUNNEL OUTDOOR

Double burner, Real Flame Burner

Natural gas (min-max): 17,000 - 44,000 BTU

Propane (min-max): 11,000 - 36,000 BTU

Efficiency: 86%

Energy efficiency class: A

Venting \varnothing (inch): 5" x 8"

Black steel: (Standard)

Black reflective panels: (Optional)

Connect to home automation: (Optional)

Operation via app - wifi kit (ProControl): (Optional)

Powerfan: (Optional)

Anti-reflective glass: (Optional)

Access door: (Optional)

Remote control: (Standard)

Convection grills built-in and surface-mounted: (Optional)

LED bottom lighting: (Optional)

SKY LT

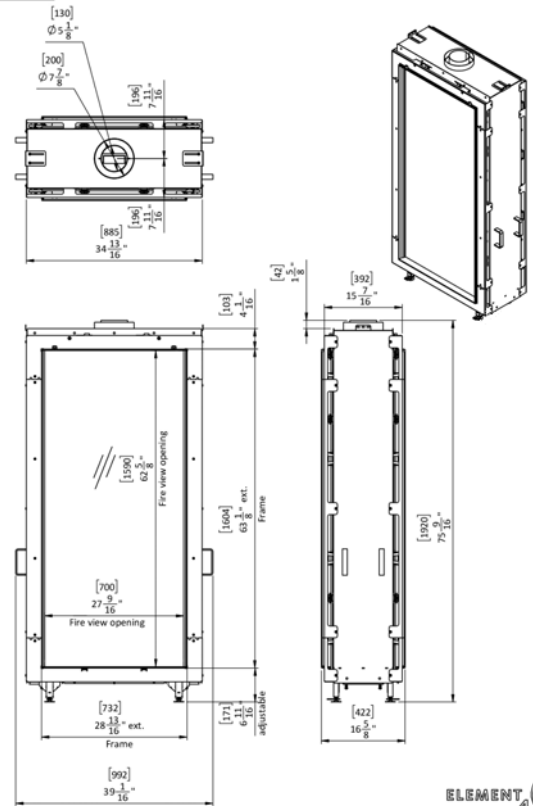

**AN EXTRAORDINARY INTERIOR NEEDS A
FIREPLACE FROM ELEMENT4**



ELEMENT
4 

